



Mack Chassis Update 2013



Stu Russoli – Marketing Product Manger Construction
John Stuart – Government and Municipal Sales Manager





Thanks to our Host



New Vocational Product Features



Floor Lighting

- Convenient Dash switch
 - Optional
- Production: August 2012



HD Front Chassis Harness

- Polyester jacket for abrasion resistance
- Production April 2013



Granite All Wheel Drive



Factory installed, full factory warranty



Interior Upgrades

- Console Storage
 - Color matched
 - 12v power outlet
 - Interior lighted
- Production: August 2012



Interior Upgrades

- Body Builder Console
 - Color matched
 - Body control mounting
 - Interface with BodyLink III
- Production: August 2012



BB Console

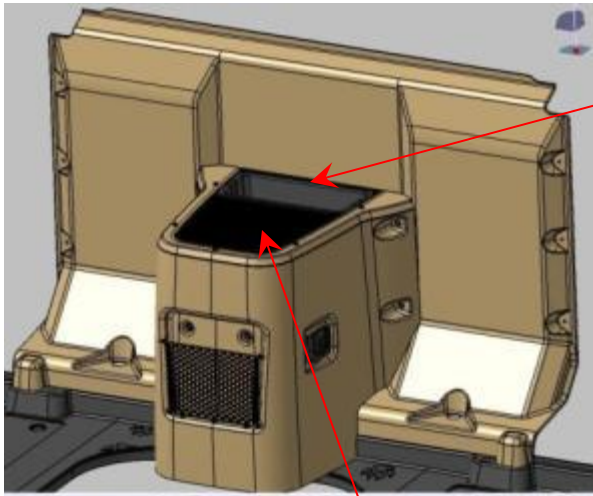

Installed view

**Mounting area for
body controls OR
hinged, locking lid
/ writing surface**

"Dispatch" Box

**Hooks (1 each side)
for hanging trash
bag**

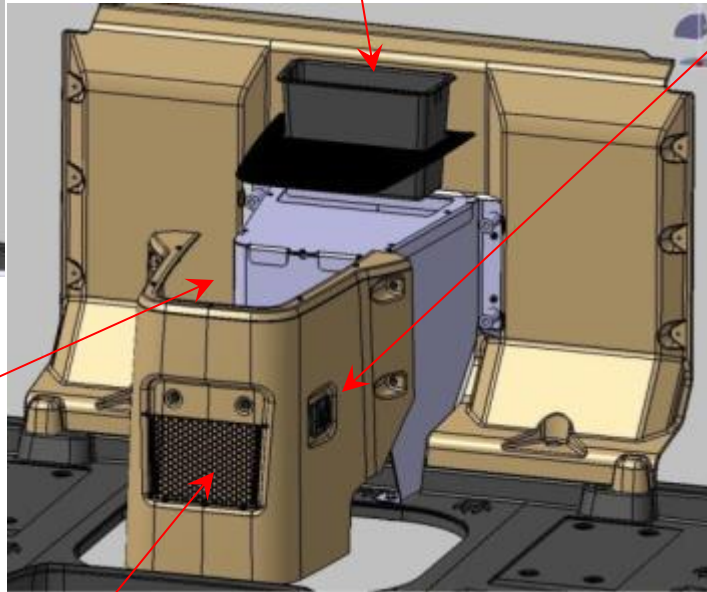

Exploded view

**Recessed storage
area covered by
expandable net**



***Removable for
Transmission Access***



BB Console



BB Console



Cab Pass Through



Cab Pass Through



BodyLink III



BodyLink III

Keep it simple! Power and lighting circuits are included. PTO inputs & remote speed control inputs to V-MAC IV are provided as well as neutral and park brake signals provided. Wiring is attached for the optional BodyLamp and assignable switch pack.

BODYLINK III BODYBUILDER CONNECTOR

POST DESCRIPTION

- 1 BATTERY POWER (30A)
- 2 IGNITION POWER (30A)
- 3 STOP LAMP
- 4 TAIL LAMP
- 5 REVERSE SIGNAL
- 6 LH TURN
- 7 RH TURN
- 8 AUX SW #1 (IGN-20A)
- 9 AUX SW #2 (BATT-15A)
- 10 AUX SW #3 (IGN-15A)
- 11 AUX SW #4 (IGN-15A)
- 12 AUX SW #5 (IGN-10A)
- 13 AUX SW #6 (DOWN-15A)
- 14 AUX SW #6 (UP-15A)
- 15 PARK BRAKE SIGNAL

POST DESCRIPTION

- 16 NEUTRAL SIGNAL
- 17 BODYLAMP GROUND INPUT
- 18 PTO #1
- 19 PTO #2
- 20 SPEED CONTROL ON/OFF
- 21
- 22
- 23 SPEED CONTROL SET/DECAL
- 24 SPEED CONTROL RESUME/ACCEL
- 25
- 26
- 27 LH TURN/STOP
- 28
- 29 RH TURN/STOP

21766567

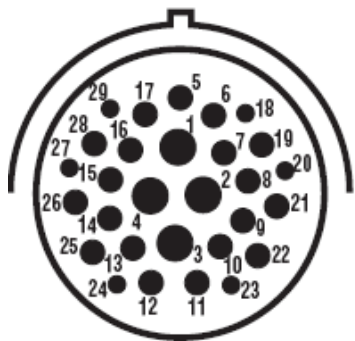

BodyLink III Assignable Switches

There is a new option for 6 assignable dash rocker switches. Switches match the existing Mack 'D' panel rockers with provisions for a removable plastic insert. The inserts carry the icon or text functions common to dump and refuse bodybuilders. The switches provide a 12v output to the BodyLink III pins #8-14.

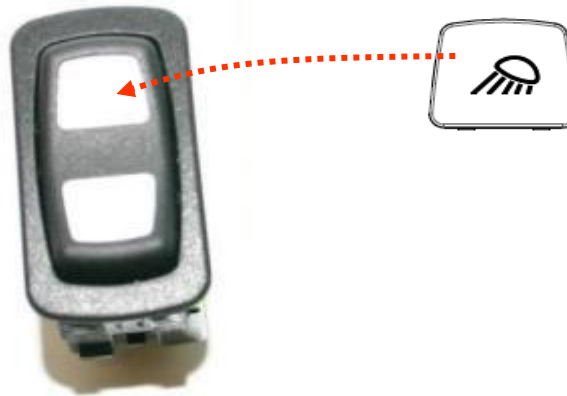

BodyLamp is carried over for US10. It illuminates when a bodybuilder input signal thru BodyLink III is grounded. Typically it is used to alert drivers that the body is in an up or partially up position.



BodyLink III Ordering

The following are relevant BodyLink III product ID (PID) codes. Existing BodyLink II PIDs are discontinued,

Ordering Information

Item	PID Code	Model	Status	Description
BodyLink III w/ Cab Pass-Thru	B83 0025	GU7, GU8	Standard (Straight)	29 pin under-cab connector, label, female connector, cab pass-thru.
BodyLink III w/o Cab Pass-Thru	B83 0026	GU7, GU8	No cost option	Same as above without pass-thru
BodyLamp	B66 0002	GU7, GU8	Optional	Body Builder Assignable Dash Lamp
Six (6) Assignable Switches	164 0012	GU7-GU8	Optional	Six (6) assignable dash rocker switches w/ labels (5 on-off, 1 momentary)



Future Product...



J1939 Interface

- 2014 CAN Bus interface production starts

J1939 Read Items	J1939 Read Items	J1939 Read Items
- Engine Speed	- Vehicle odometer	- SCR tank level
- Vehicle Speed	- Engine coolant temperature	- Air application pressure
- Engine % Load	- Engine oil pressure	- Left & right turn signal
- Brake Pedal Switch Status	- Total fuel consumed	- Clearance/marker lamp status
- Parking Brake Switch Status	- Fuel level	- Allison sump temperature
- Engine hours	- Fuel rate	- Allison current gear
		- Allison selected gear

A summary list of refuse bodybuilder J1939 commands (for OEM to obey):

J1939 Command Items	J1939 Command Items	J1939 Command Items
- Engine RPM command	- Go to neutral command	- PTO1 & PTO2 Activation
- Engine % Load / % throttle command	- Vehicle Speed Limit	
	- Transmission Range Limit	



Air Disc Brakes

- New Stopping Distance Requirements (FMVSS)
 - Phase 1: Meet mandate
 - Production: July 2013
 - Phase 2: Group solution
 - Production: February 2014



To be announced

- Mack's got your back
- Announcement coming soon
- Combining purposeful technology with the human know-how of the Mack support network
- Keeping you rolling and profits churning



Natural Gas



Mack Customer Center

Allentown, PA

Showcase for MACK[®] products and company heritage

- Product showroom with newest truck models on display
- Heritage Center featuring 113 years of Mack history
- Mack Museum with antique trucks and artifacts
- Performance track to let customers get behind the wheel
- Specialty vehicle options center onsite



An aerial photograph of a large industrial facility, the Macungie Assembly Operations. The main building is a long, rectangular structure with a grey roof, divided into several sections. To the right of the main building is a large parking lot filled with numerous cars and trucks. Further to the right, there are several smaller, white, rectangular buildings. The facility is surrounded by green fields and trees. In the background, a residential area with houses is visible.

Opened 1975
Property: 151 acres
Under Roof: 929K Sq.Ft.
Approx. Employees: 1100

**Macungie Assembly Operations,
Macungie, PA**

Opened 1961

Property: 281 Acres

Under Roof: 1.5M sq. ft.

Employees: Approx. 1250 on site



Mack Powertrain, Hagerstown, MD

IT TAKES MORE THAN A TRUCK TO GO THE DISTANCE.



Customers count on you to deliver the goods. You need a truck and a company behind the truck you can depend on. With Pedigree Uptime Protection, Mack® has integrated solutions that support your business, from financing to service and beyond. Put it all together and you've got everything you need to keep you on the road longer and get you back on the road faster. That's just one way Mack has your back.

LIVE BY THE CODE. DRIVE BY THE CODE.



MackTrucks.com





PEDIGREE UPTIME PROTECTION



New Level of Integration

New Standard in Total Business Solutions





Bulldog Service Management

- Customers and service providers work together to speed repairs and increase uptime
- Access to fast, complete and accurate estimates
- Multiple language breakdown support, including towing arrangements
- Scheduling for preventive maintenance
- Real-time online case tracking

Powered by MVASIST and Mack OneCall





Bulldog Parts Purchasing

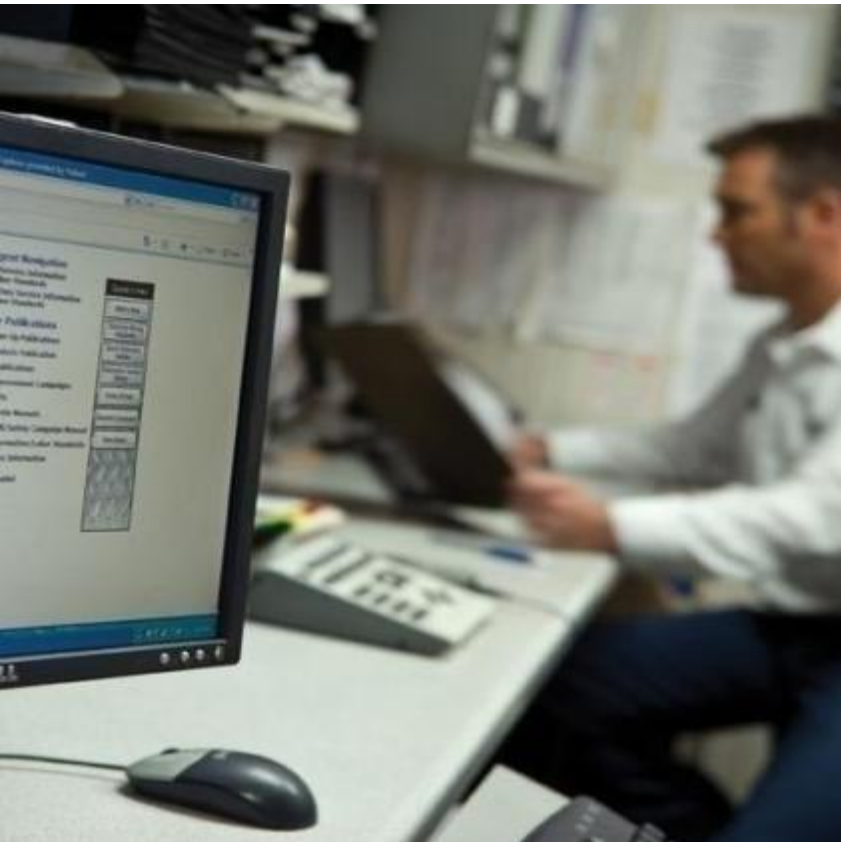

Internet parts ordering through local Mack dealer

- Convenience of round-the-clock parts availability and price inquiry
- Access to over 500,000 vendor brand aftermarket parts
- Online access to purchase and invoice history









Under Construction

ADOT



Coming Soon



Autumn 2013





AN AMERICAN LEGEND

STILL BUILT IN THE U.S.A.

113 YEARS LATER

Thank You!



BUILT LIKE A MACK TRUCK®